

## Wire Mesh Tray System

 Wire Mesh Tray

 Barrier Strips

 Covers

 Accessories



All straight sections of cable tray as well as their corresponding system components (fittings, splice plates, covers, ...) are classified by UL in accordance with NEMA VE 1 for the USA and CSA E22.2 No. 126.1 for Canada.

Please add an 'X' after the first sequence of characters in the part number to get your products labeled for UL conformity (f.e. RLV 60.200 becomes RLVX 60.200 or GRS 110.300 becomes GR SX 110.300).



Wire Mesh Tray is lightweight, flexible and easy to install. Due to its small surface area there is no accumulation of dirt or humidity. Cable ventilation is perfect.











There is no need for long term advanced planning and ordering. Just get straight sections of tray, a few accessories like the universal splice kit and a bolt cutter and you are ready to go. All kinds of fittings can be done onsite easily.

Wire Mesh Tray is available in many finishes and can be used in industrial and commercial environments, inside and outside.



# WIRE MESH TRAY SYSTEM

## Available Side Rail Heights

SYSTEM	Wire Mesh Tray	GR	 Page 142	 Page 142	 Page 143	 —	 —
	Wire Mesh Tray, u-shaped	GRS	 —	 —	 Page 143	 Page 145	 Page 146
ACCESSOIRES	Barrier Strip	RW	Page 148*				
	Splice Plate for Barrier Strip	RTV	Page 148*				
	Boltless Splice Plate	GRVS	Page 148*				
	Universal Splice Plate	GRV 6	Page 148*				
	Mounting Clamp for Barrier Strip	GRVC 14	Page 149*				
	Wire Mesh Bracket	GRWGK 10	Page 149*				
	Wall Support and Center Hanger	GRWB 10	Page 150*				
	Mounting with Threaded Rod	GRKB 10	Page 150*				
	J-Hook Bolt	GRSM 6	Page 150*				
	Trapeze Hanger Clip	GRAB 10	Page 151*				
	Mounting Bracket	GRMB 50	Page 152*				
	Overhead Hanger	GRTS 30/3	Page 152*				
	Bracket for Wire Mesh Tray	GRHB 30/150	Page 153*				
	Slotted Mushroom Head Bolt	FLM 8 x 16	Page 153*				
	Standard Hanger	GRSH 30	Page 153*				
	Overhead Hanger	GRHS	Page 154*				
	Horizontal 90° Splice Plate	GRWV 20/250	Page 154*				
	Universal Mounting Bracket	GRB	Page 154*				
	Fixing Bracket	GRBB 6 V	Page 154*				
	Cover for Wire Mesh Tray	GRD	Page 155*				

\* Applicable with all edge heights

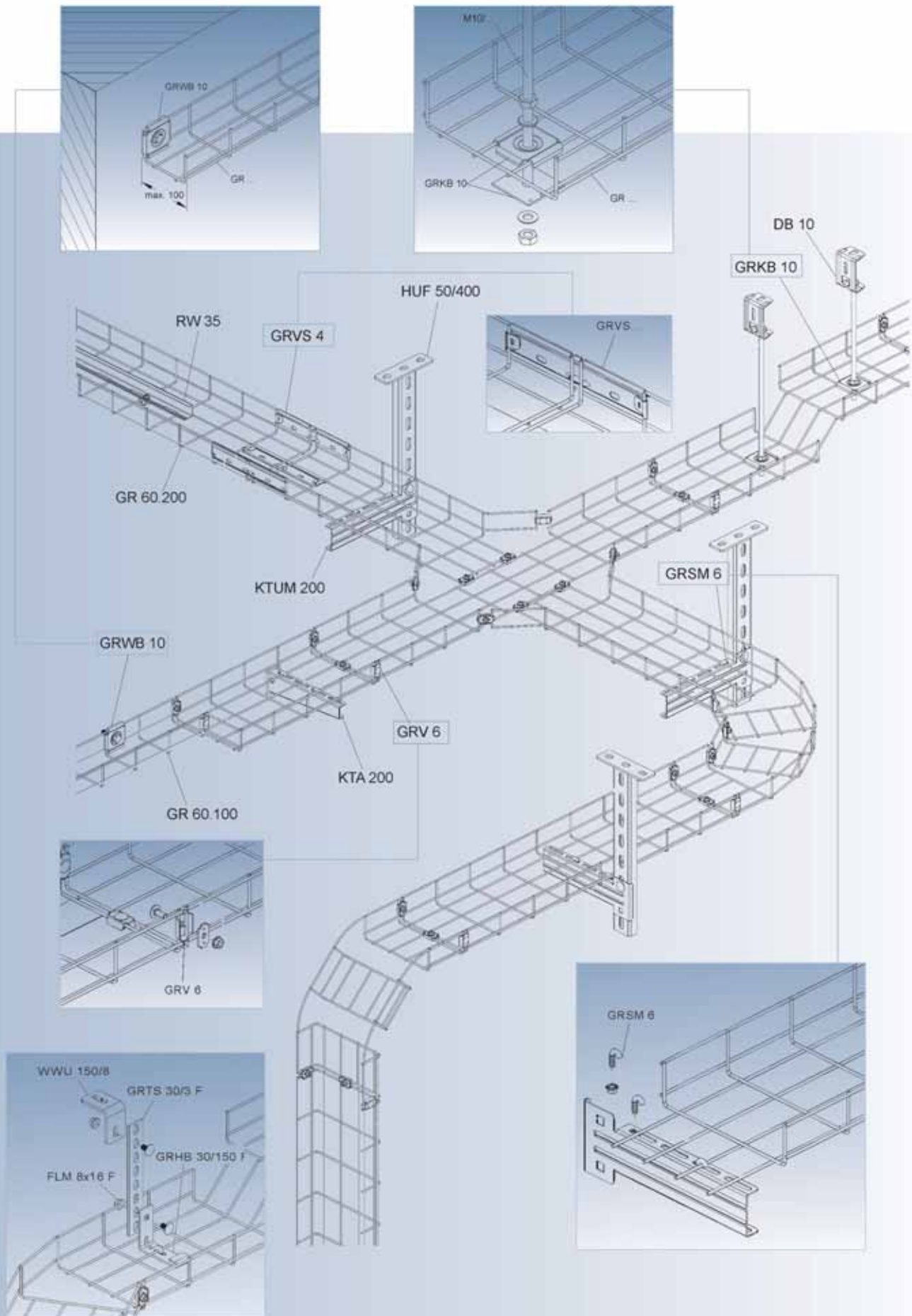

## Wire Mesh Cable Tray Specifications:

### A. CABLE TRAY DESIGN

1. Wire mesh cable tray shall utilize high mechanical strength steel wire that is welded into a 2" x 4" (50 mm x 100 mm) grid system. This grid is then formed into channels, which support and carry cables and permit ventilation of cables and maximum heat dissipation.

### B. MATERIAL

1. **Electro-plated zinc galvanized: ASTM B633.**  
To be applied to welded and formed wire mesh surfaces.
2. **Hot dipped galvanized steel.**  
All trays to be hot-dipped galvanized after fabrication in accordance with ASTM A123.
3. **Stainless steel.**  
All trays are to be constructed of AISA type 304 or type 316 stainless steel for maximum corrosion resistance
4. **Epoxy Powder Coated Paint:**  
available on special request

### C. Tray Size

1. **Height:** Trays shall have an overall height of 1.4", 2.3", 4.3", and 6.3" (35, 60, 110 and 160 mm)
2. **Width:** Widths shall be 2", 4", 6", 8", 12", 16", 18" 20" and 24" (60, 100, 150, 200, 300, 400, 450, 500 and 600 mm).
3. **Length:** Length shall be a nominal 10' or 3 meters.

### D. FITTINGS:

1. Shall be fabricated in the field by cutting wires with offset blade bolt cutters. Cuts shall be made in a manner reducing sharp edges and projections so they do not harm cables or installation personnel.
2. Dividers. Provide pre-galvanized steel, full depth divider strips to follow the contours of the mesh sections to allow different wiring systems to be run in the same tray.
3. Supports: Manufacturers specified supports and hardware are to be used for installation
4. Splices: Two options available, bolted type or non bolted to splice sections end to end, in pre-galvanized steel, hot dipped galvanized steel, and stainless steel.

### E. UL CLASSIFICATION

1. Straight sections shall be UL classified as an equipment grounding conductor

### F. DESIGN AND MANUFACTURE

1. GRX/GRSX series cable tray shall be manufactured by The Niedax Group.

**Load / Span Class Designation in accordance  
with NEMA VE 1 and CSA E22.2 No. 126.1**

NIEDAX Series	Minimum Area		Load class in accordance to NEMA VE 1		
	(calculational) mm <sup>2</sup> / in. <sup>2</sup>	in accordance to NEMA VE 2 mm <sup>2</sup> / in. <sup>2</sup>	Rated Load Kg/m / lb./ft.	Support spacing m / ft.	Load/Span Class
GRX 35.100, ... F	38 / 0.06	-	12 / 8.1	2 / 6.6	-
GRX 35.150, ... F	48 / 0.07	-	12 / 8.1	2 / 6.6	-
GRX 35.200, ... F	58 / 0.09	-	12 / 8.1	2 / 6.6	-
GRX 35.300, ... F	101 / 0.16	-	16.5 / 11.1	2 / 6.6	-
GRX 35.400, ... F	126 / 0.19	-	16.5 / 11.1	2 / 6.6	-
GRX 40.040, ... F	38 / 0.06	-	42.7 / 28.8	1 / 3.3	-
GRX 60.100, ... F, ... E3	58 / 0.09	-	16.5 / 11.1	2 / 6.6	-
GRX 60.150, ... F, ... E3	67 / 0.10	-	16.5 / 11.1	2 / 6.6	-
GRX 60.200, ... F, ... E3	77 / 0.12	-	16.5 / 11.1	2 / 6.6	-
GRX 60.300, ... F, ... E3	126 / 0.19	-	31.5 / 21.2	2 / 6.6	-
GRX 60.400, ... F, ... E3	151 / 0.23	129 / 0.2	31.5 / 21.2	2 / 6.6	-
GRSX 60.060, ...F ...E3	64 / 0.10	-	25.5 / 17.1	2 / 6.6	-
GRSX 60.100, ...F ...E3	75 / 0.12	-	25.5 / 17.1	2 / 6.6	-
GRSX 60.150, ...F ...E3	111 / 0.17	-	25.5 / 17.1	2 / 6.6	-
GRSX 60.200, ...F ...E3	127 / 0.20	-	25.5 / 17.1	2 / 6.6	-
GRSX 60.300, ...F ...E3	181 / 0.28	129 / 0.2	63 / 42.3	2 / 6.6	A
GRSX 60.400, ...F ...E3	217 / 0.34	129 / 0.2	63 / 42.3	2 / 6.6	A
GRSX 60.500, ...F ...E3	253 / 0.39	129 / 0.2	63 / 42.3	2 / 6.6	A
GRX 110.100, ... F	77 / 0.12	-	53.3 / 35.9	2 / 6.6	-
GRX 110.200, ... F	125 / 0.19	-	53.3 / 35.9	2 / 6.6	-
GRX 110.300, ... F	151 / 0.23	129 / 0.2	53.3 / 35.9	2 / 6.6	-
GRX 110.400, ... F	175 / 0.27	129 / 0.2	53.3 / 35.9	2 / 6.6	-
GRX 110.500, ... F	201 / 0.31	129 / 0.2	53.3 / 35.9	2 / 6.6	-
GRX 110.600, ... F	226 / 0.35	129 / 0.2	53.3 / 35.9	2 / 6.6	-
GRSX 110.200, ... F	181 / 0.28	129 / 0.2	83.3 / 56	2 / 6.6	A
GRSX 110.300, ... F	217 / 0.34	129 / 0.2	83.3 / 56	2 / 6.6	A
GRSX 110.450, ... F	271 / 0.42	258 / 0.4	83.3 / 56	2 / 6.6	A
GRSX 110.600, ... F	326 / 0.50	258 / 0.4	103.3 / 69.4	2 / 6.6	A
GRSX 110.200, ... E3	159 / 0.25	129 / 0.2	50 / 33.6	2 / 6.6	-
GRSX 110.300, ... E3	191 / 0.30	129 / 0.2	50 / 33.6	2 / 6.6	-
GRSX 110.450, ... E3	239 / 0.37	129 / 0.2	50 / 33.6	2 / 6.6	-
GRSX 110.600, ... E3	286 / 0.44	258 / 0.4	60 / 40.3	2 / 6.6	-
GRSX 160.200, ... F	217 / 0.34	129 / 0.2	83.3 / 56	2 / 6.6	A
GRSX 160.300, ... F	253 / 0.39	129 / 0.2	83.3 / 56	2 / 6.6	A
GRSX 160.450, ... F	308 / 0.48	258 / 0.4	83.3 / 56	2 / 6.6	A
GRSX 160.600, ... F	362 / 0.56	258 / 0.4	123.3 / 82.9	2 / 6.6	A
GRSX 160.200, ... E3	191 / 0.30	129 / 0.2	56.7 / 38.1	2 / 6.6	-
GRSX 160.300, ... E3	223 / 0.35	129 / 0.2	56.7 / 38.1	2 / 6.6	-
GRSX 160.450, ... E3	270 / 0.42	258 / 0.4	56.7 / 38.1	2 / 6.6	-
GRSX 160.600, ... E3	318 / 0.49	258 / 0.4	73.3 / 49.3	2 / 6.6	A

# WIRE MESH TRAY SYSTEM

## Wire Mesh Tray

model no.	height (H)	width B	thick-ness (t)	EAN code	Weight per 100 m kg
	mm/Inch	mm/Inch	mm/Inch		
V GR 35.100	35/1,4	100/3,9	3,5	279524	42
V GR 35.150	35/1,4	150/5,8	3,5	781003	54
V GR 35.200	35/1,4	200/7,8	3,5	279531	65
V GR 35.300	35/1,4	300/11,7	4	279548	115
F GR 35.100 F	35/1,4	100/3,9	3,5	909100	41,6
F GR 35.150 F	35/1,4	150/5,8	3,5	909124	53,3
F GR 35.200 F	35/1,4	200/7,8	3,5	909148	65
F GR 35.300 F	35/1,4	300/11,7	4	909162	115
F GR 35.400 F	35/1,4	400/15,6	4	909186	145

Splice plates to be ordered separately.

Load Chart: q = uniformly distributed load (tested according to DIN EN IEC 61537 standard)

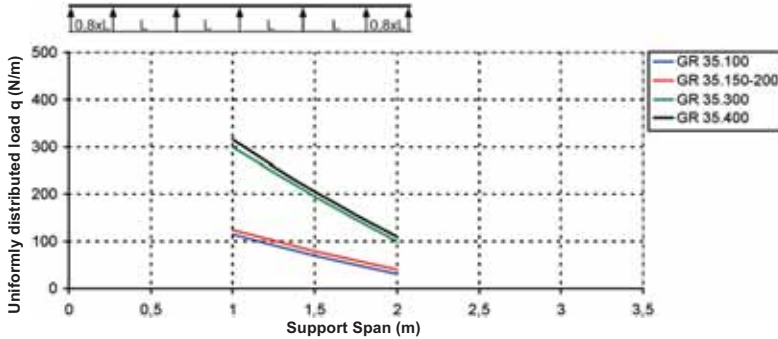

Specified load ratings are independent of splice plate location.

35

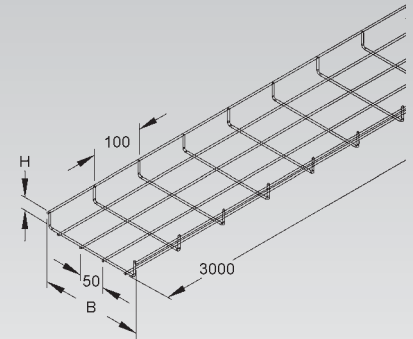

## Wire Mesh Tray

model no.	height (H)	width B	thick-ness (t)	EAN code	Weight per 100 m kg
	mm/Inch	mm/Inch	mm/Inch		
V GR 40.040	40/1,6	40/1,6	3,5	909209	37,6
F GR 40.040 F	40/1,6	40/1,6	3,5	909223	37,6
E3 GR 40.040 E3	40/1,6	40/1,6	3,5	343713	37,6

Splice plates to be ordered separately.

GRV 6 splice has to be ordered separately.

Load Chart: q = uniformly distributed load (tested according to DIN EN IEC 61537 standard)

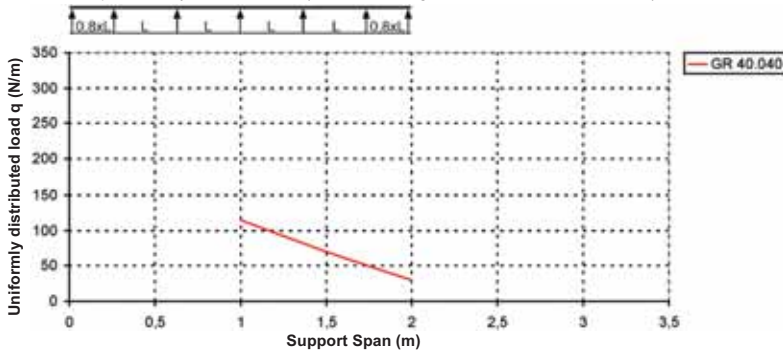

Specified load ratings are independent of splice plate location.

40

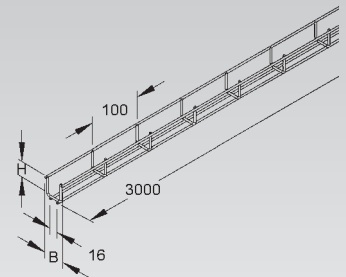

## Wire Mesh Tray

model no.	height (H)	width B	thick-ness (t)	EAN code	Weight per 100 m kg
	mm/Inch	mm/Inch	mm/Inch		
V GR 60.100	60/2,3	100/3,9	3,5	279562	62
V GR 60.150	60/2,3	150/5,8	3,5	781102	74
V GR 60.200	60/2,3	200/7,8	3,5	279579	84
V GR 60.300	60/2,3	300/11,7	4	279586	140
V GR 60.400	60/2,3	400/15,6	4	279593	170
V GR 60.500	60/2,3	500/19,5	4	870707	199
V GR 60.600	60/2,3	600/23,4	4	870752	229
F GR 60.100 F	60/2,3	100/3,9	3,5	870806	62
F GR 60.150 F	60/2,3	150/5,8	3,5	870813	73,3
F GR 60.200 F	60/2,3	200/7,8	3,5	870820	84
F GR 60.300 F	60/2,3	300/11,7	4	870844	140
F GR 60.400 F	60/2,3	400/15,6	4	870868	170
F GR 60.500 F	60/2,3	500/19,5	4	870882	199
F GR 60.600 F	60/2,3	600/23,4	4	870899	229
E3 GR 60.100 E3	60/2,3	100/3,9	3,5	343720	62
E3 GR 60.150 E3	60/2,3	150/5,8	3,5	343737	74
E3 GR 60.200 E3	60/2,3	200/7,8	3,5	343744	84
E3 GR 60.300 E3	60/2,3	300/11,7	4	343768	140
E3 GR 60.400 E3	60/2,3	400/15,6	4	343782	170

Splice plates to be ordered separately.

Load Chart: q = uniformly distributed load (tested according to DIN EN IEC 61537 standard)

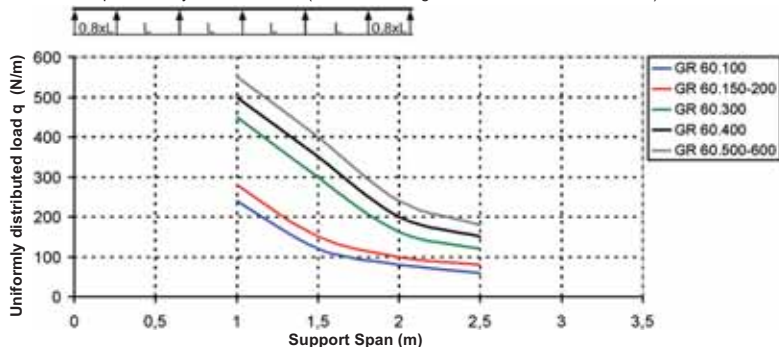

Specified load ratings are independent of splice plate location.

60

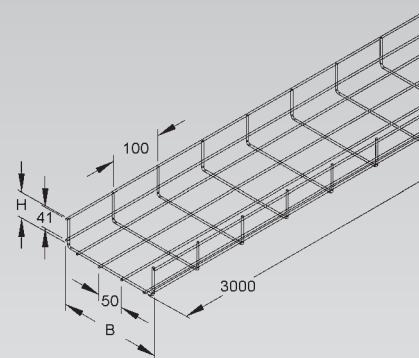

## Wire Mesh Tray

model no.	height (H)	width B	thick-ness (t)	EAN code	Weight per 100 m kg
	mm/Inch	mm/Inch	mm/Inch		
V GRS 60.060	60/2,3	60/2,3	4	781904	56
F GRS 60.060 F	60/2,3	60/2,3	4	892204	59,3
E3 GRS 60.060 E3	60/2,3	60/2,3	4,5	801152	70

Splice plates to be ordered separately.

Load Chart: q = uniformly distributed load (tested according to DIN EN IEC 61537 standard)

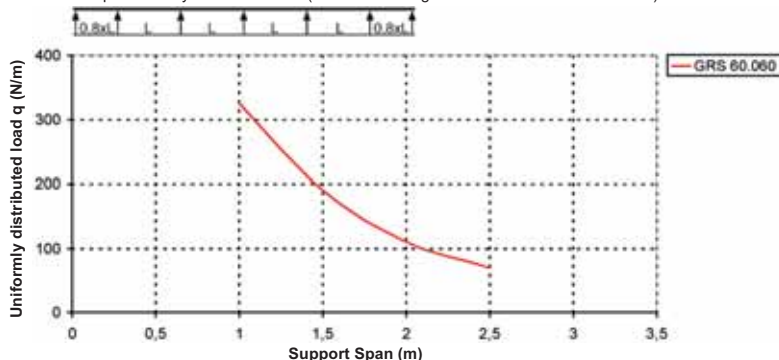

Specified load ratings are independent of splice plate location.

60

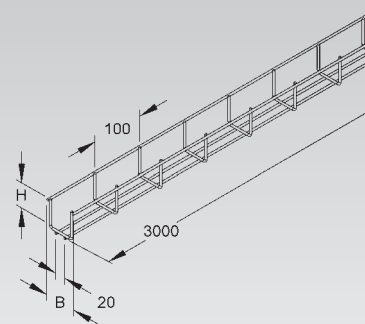



# WIRE MESH TRAY SYSTEM

## Wire Mesh Tray

model no.	height (H) mm/Inch	width B mm/Inch	thick-ness (t) mm/Inch	EAN code	Weight per 100 m kg
V GRS 60.100	60/2,3	100/3,9	4	781928	80
V GRS 60.150	60/2,3	150/5,8	4,5	781942	119
V GRS 60.200	60/2,3	200/7,8	4,5	781966	138
V GRS 60.300	60/2,3	300/11,7	4,8	781980	200
V GRS 60.400	60/2,3	400/15,6	4,8	782000	244
V GRS 60.500	60/2,3	500/19,5	4,8	782024	287
V GRS 60.600	60/2,3	500/19,5	4,8	782048	333
F GRS 60.100 F	60/2,3	100/3,9	4	892228	85,3
F GRS 60.150 F	60/2,3	150/5,8	4,5	892242	127
F GRS 60.200 F	60/2,3	200/7,8	4,5	892266	148,3
F GRS 60.300 F	60/2,3	300/11,7	4,8	892280	214
F GRS 60.400 F	60/2,3	400/15,6	4,8	892303	261,6
F GRS 60.500 F	60/2,3	500/19,5	4,8	892327	307,6
E3 GRS 60.100 E3	60/2,3	100/3,9	4,5	801169	99,3
E3 GRS 60.150 E3	60/2,3	150/5,8	4,5	801176	118,3
E3 GRS 60.200 E3	60/2,3	200/7,8	4,5	801183	139
E3 GRS 60.300 E3	60/2,3	300/11,7	4,5	903528	177
E3 GRS 60.400 E3	60/2,3	400/15,6	4,5	903542	215
E3 GRS 60.500 E3	60/2,3	500/19,5	4,5	903566	253
E3 GRS 60.600 E3	60/2,3	600/23,4	4,5	903580	295

Splice plates to be ordered separately.

Load Chart: q = uniformly distributed load (tested according to DIN EN IEC 61537 standard)

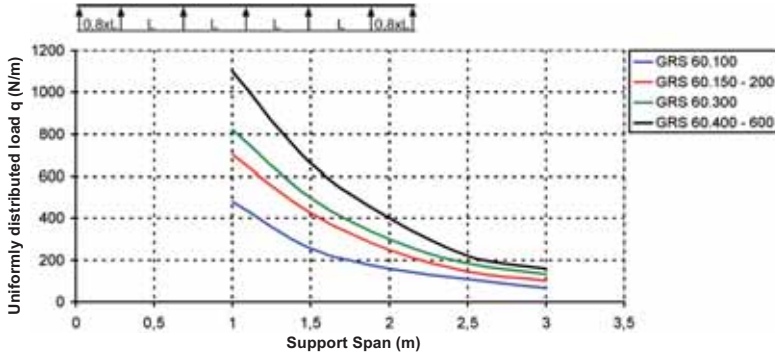

Specified load ratings are independent of splice plate location.

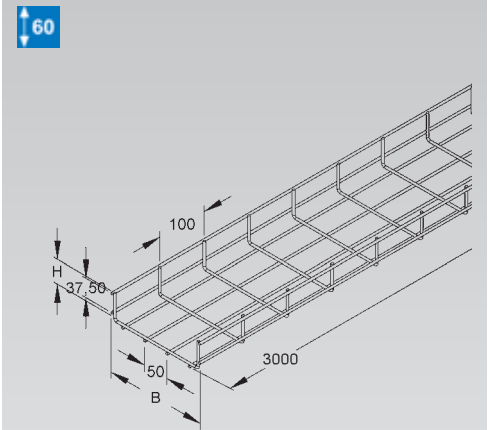

### Wire Mesh Tray

model no.	height (H)	width B	thick-ness (t)	EAN code	Weight per 100 m kg
	mm/Inch	mm/Inch	mm/Inch		
V GRS 110.200	110/4,3	200/7,8	4,8	930517	
V GRS 110.300	110/4,3	300/11,7	4,8	930524	
V GRS 110.450	110/4,3	450/17,6	4,8	933969	306,9
V GRS 110.600	110/4,3	600/23,4	4,8	930555	
F GRS 110.200 F	110/4,3	200/7,8	4,8	930579	
F GRS 110.300 F	110/4,3	300/11,7	4,8	930586	
F GRS 110.450 F	110/4,3	450/17,6	4,8	933976	329,9
F GRS 110.600 F	110/4,3	600/23,4	4,8	930616	

Splice plates to be ordered separately.

Load Chart: q = uniformly distributed load (tested according to DIN EN IEC 61537 standard)

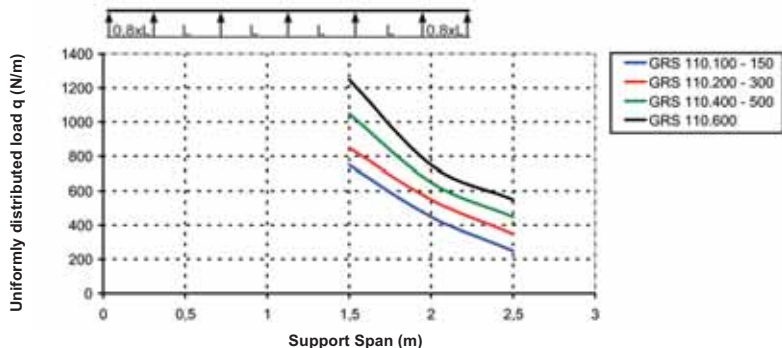

Specified load ratings are independent of splice plate location.

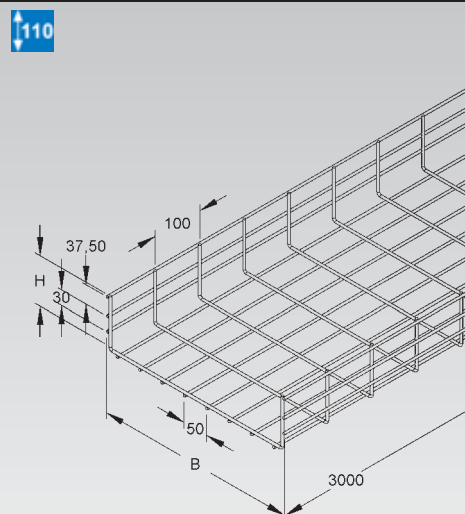

### Wire Mesh Tray

model no.	height (H)	width B	thick-ness (t)	EAN code	Weight per 100 m kg
	mm/Inch	mm/Inch	mm/Inch		
E3 GRS 110.200 E3	110/4,3	200/7,8	4,5	930739	
E3 GRS 110.300 E3	110/4,3	300/11,7	4,5	930746	
E3 GRS 110.450 E3	110/4,3	450/17,6	4,5	934041	271,6
E3 GRS 110.600 E3	110/4,3	600/23,4	4,5	930777	

Splice plates to be ordered separately.

Load Chart: q = uniformly distributed load (tested according to DIN EN IEC 61537 standard)

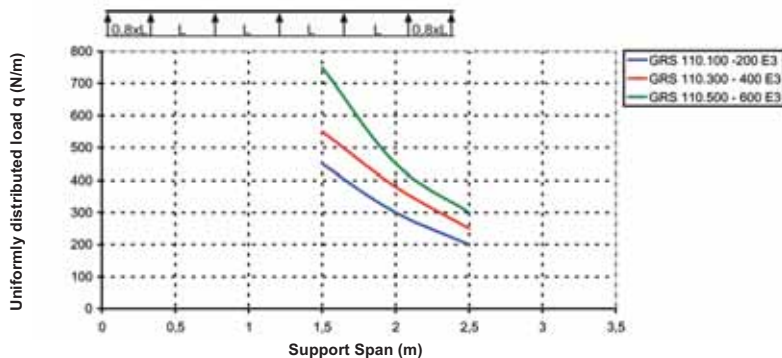

Specified load ratings are independent of splice plate location.

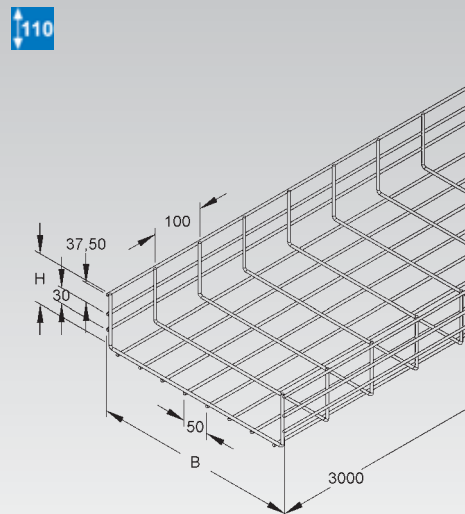

# WIRE MESH TRAY SYSTEM

## Wire Mesh Tray

model no.	height (H)	width B	thick-ness (t)	EAN code	Weight per 100 m kg
	mm/Inch	mm/Inch	mm/Inch		
V GRS 160.200	160/6,2	200/7,8	4,8	930623	
V GRS 160.300	160/6,2	300/11,7	4,8	930630	
V GRS 160.450	160/6,2	450/17,6	4,8	934010	350
V GRS 160.600	160/6,2	600/23,4	4,8	930661	
F GRS 160.200 F	110/4,3	200/7,8	4,8	930678	
F GRS 160.300 F	110/4,3	300/11,7	4,8	930685	
F GRS 160.450 F	110/4,3	450/17,6	4,8	934027	376,3
F GRS 160.600 F	110/4,3	600/23,4	4,8	930715	

Splice plates to be ordered separately.

Load Chart: q = uniformly distributed load (tested according to DIN EN IEC 61537 standard)

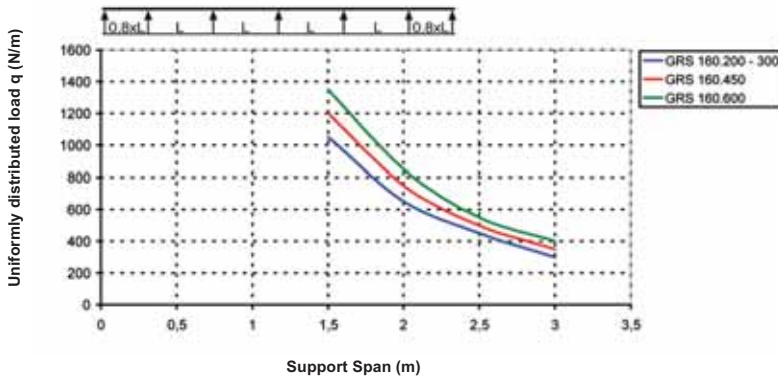

Specified load ratings are independent of splice plate location.

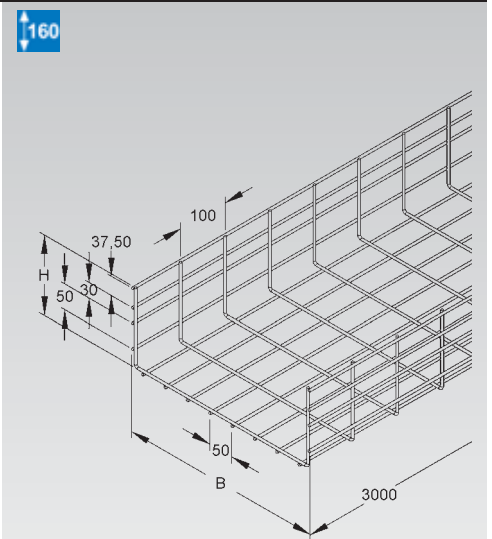

## Wire Mesh Tray

model no.	height (H)	width B	thick-ness (t)	EAN code	Weight per 100 m kg
	mm/Inch	mm/Inch	mm/Inch		
E3 GRS 160.200 E3	160/6,2	200/7,8	4,5	930845	
E3 GRS 160.300 E3	160/6,2	300/11,7	4,5	930852	
E3 GRS 160.450 E3	160/6,2	450/17,6	4,5	934072	309,8
E3 GRS 160.600 E3	160/6,2	600/23,4	4,5	930883	

Splice plates to be ordered separately.

Load Chart: q = uniformly distributed load (tested according to DIN EN IEC 61537 standard)

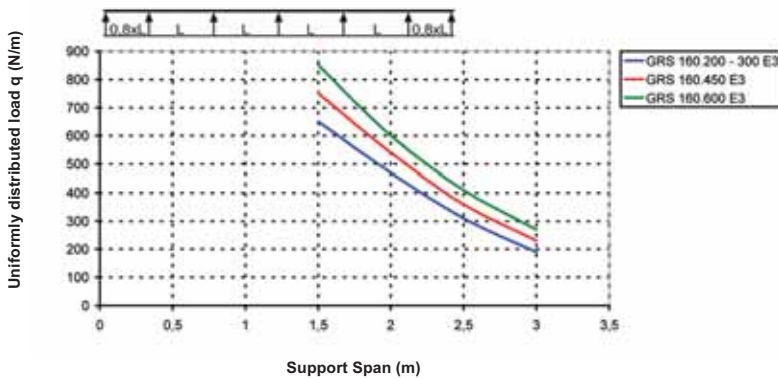

Specified load ratings are independent of splice plate location.

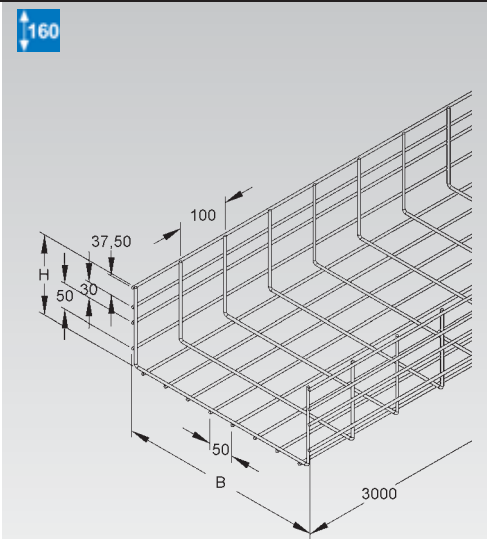

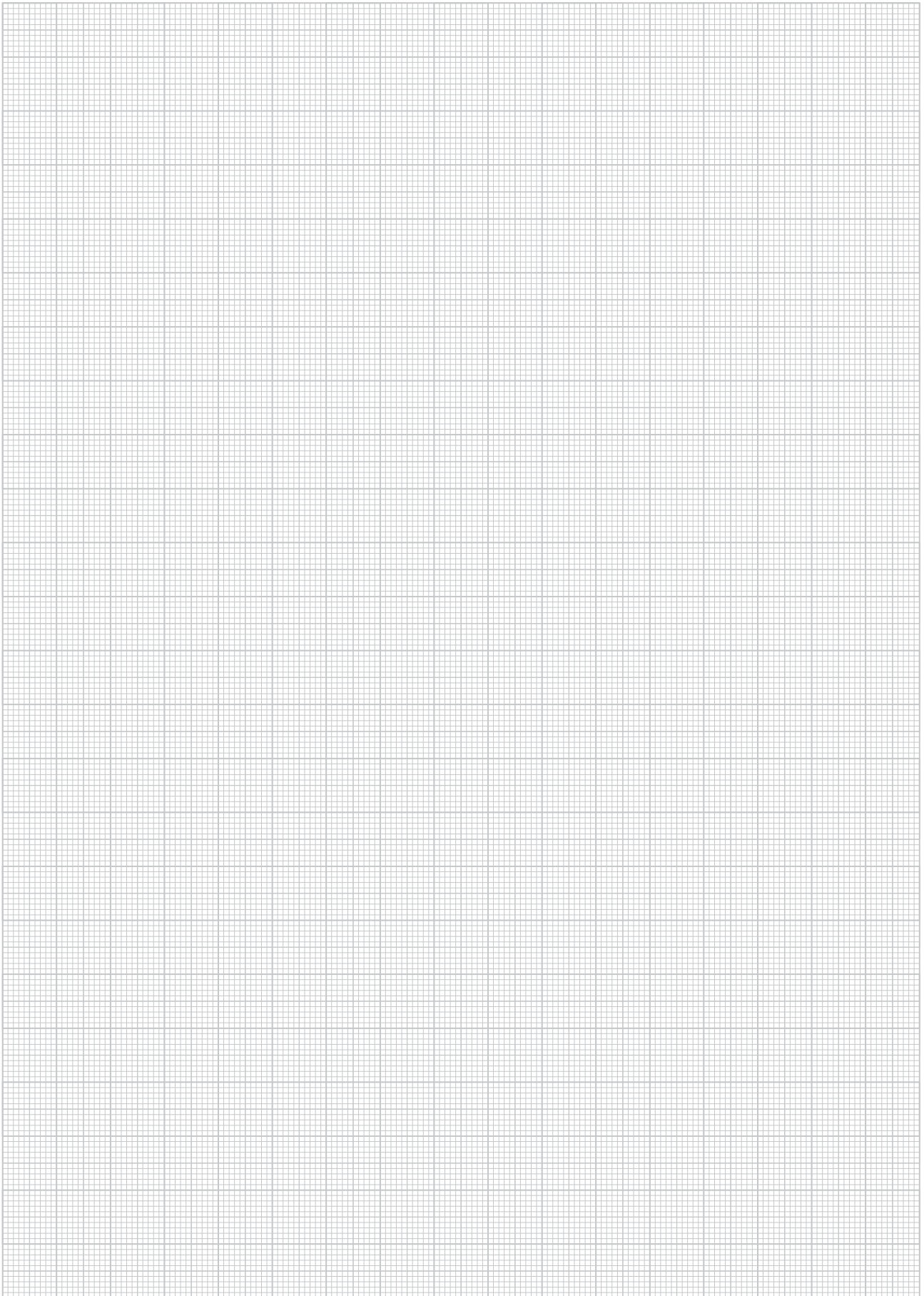

# WIRE MESH TRAY SYSTEM ACCESSORIES

## Barrier Strip

model no.	height (H) mm/Inch	thick-ness (t) mm/Inch	acc. incl.	EAN code	Weight per 100 m kg
S RW 35	30/1,2	0,75	4 FLM 6x12	213504	35
S RW 50	47/1,8	0,75	4 FLM 6x12	224951	45
S RW 60	55/2,1	0,75	4 FLM 6x12	225002	50
S RW 85	80/3,1	0,9	4 FLM 6x12	237609	92
S RW 110	98/3,8	0,9	4 FLM 6x12	251001	90
F RW 35 F	30/1,2	0,75	4 FLM 6x12 F	213603	35
F RW 60 F	55/2,1	0,75	4 FLM 6x12 F	225101	50
F RW 85 F	80/3,1	0,9	4 FLM 6x12 F	237708	92
F RW 110 F	98/3,8	0,9	4 FLM 6x12 F	251100	90
E3 RW 50 E3	47/1,8	0,8	4 FLM 6x12 E3	333356	45

to separate wires and cables of different voltage levels or with different functions

Continuous perforation allows mounting without gradation. Slots (7x38 mm) are spaced at 100 mm.

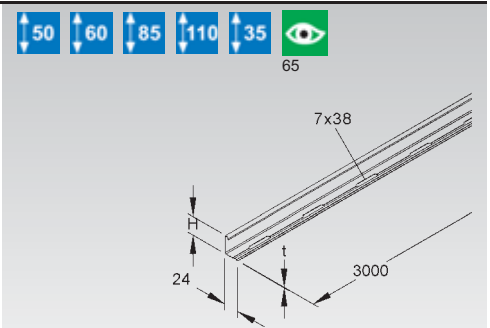

## Splice Plate for Barrier Strip

model no.	height (H) mm/Inch	length (A) mm/Inch	EAN code	Weight per 100 pc. kg
E2 RTV 35 E2	29/1,1	80/3,1	213658	1
E2 RTV 50 E2	46,5/1,8	80/3,1	224999	1
E2 RTV 60 E2	54,5/2,1	80/3,1	225149	1,5
E2 RTV 85 E2	79,5/3,1	80/3,1	237753	2
E2 RTV 110 E2	97,5/3,8	80/3,1	251162	3

for positive locking connections of barrier strips with proper electrical conductivity

Barrier strips are connected by means of a special splice plate.

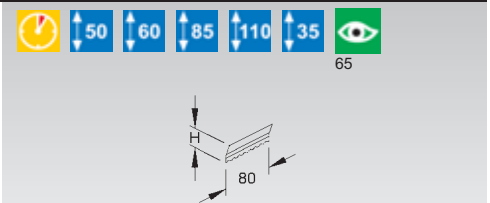

## Boltless Splice Plate

for wire mesh tray with 100 mm cross wire distance

model no.	height (H) mm/Inch	length (A) mm/Inch	for wire gauge mm/Inch	EAN code	Weight per 100 pc. kg
S GRVS 4	36/1,4	220/8,6	3,5 - 4,0	280353	8,5
S GRVS 5	36/1,4	220/8,6	4,0 - 5,0	280377	8,3
E3 GRVS 4 E3	36/1,4	220/8,6	3,5 - 4,0	781201	6
E3 GRVS 5 E3	36/1,4	220/8,6	4,0 - 5,0	340118	8

for making straight runs of wire mesh tray

use GRVS... E3 (stainless steel) for hot dip galvanized wire mesh tray

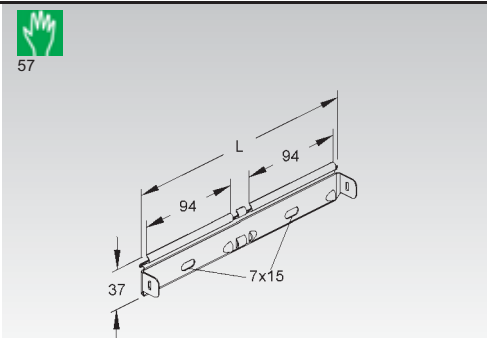

## Universal Splice Plate

for wire mesh tray, two parts

model no.	acc. incl.	EAN code	Weight per 100 pc. kg
S GRV 6	1 FLM 6x16	280209	3,5
F GRV 6 F	1 FLM 6x16 F	280186	2,8
E3 GRV 6 E3	1 FLM 6x16 E3	802104	3,5

for making straight runs of wire mesh tray and fittings for wire mesh tray

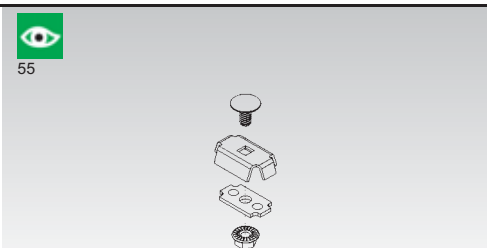

### Mounting Clamp for Barrier Strip

for wire mesh tray

model no.	acc. incl.	EAN code	Weight per 100 pc. kg
<b>S</b> GRVC 14	1 FLM 6x16	280308	3
<b>F</b> GRVC 14 F	1 FLM 6x16 F	280339	3
<b>E3</b> GRVC 14 E3	1 FLM 6x16 E3	841509	3

for attaching barrier strip in wire mesh tray

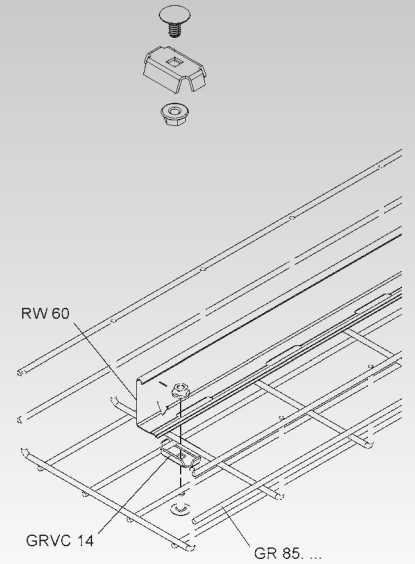

### Wire Mesh Mounting Bracket

model no.	EAN code	Weight per 100 pc. kg
★ <b>S</b> GRWGK 10 S	280797	5,8
★ <b>E3</b> GRWGK 10 E3	931057	5,8

for flexible wall or ceiling mounting of wire mesh tray

Can be used for all kinds of wire mesh tray from wire gauge 3.0 mm to 6.0 mm. GR 40.040 and GRS 60.060 are supported as well.



56

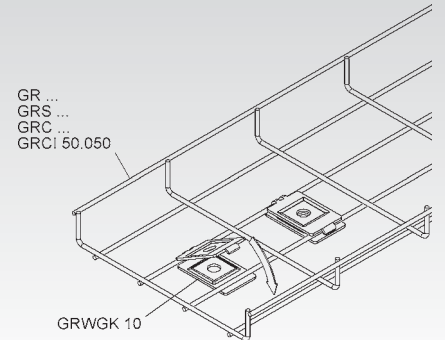
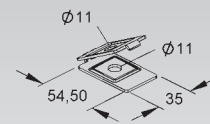

# WIRE MESH TRAY SYSTEM ACCESSORIES

## Wall Bracket and Floor Support

for wire mesh tray

model no.	EAN code	Weight per 100 pc. kg
<b>S</b> GRWB 10	280605	6
<b>F</b> GRWB 10 F	280650	6,5
<b>E3</b> GRWB 10 E3	802005	5

for wall mounting wire mesh tray (max. width 100 mm)

for floor mounting of wire mesh tray (50 mm length wire distance)



56

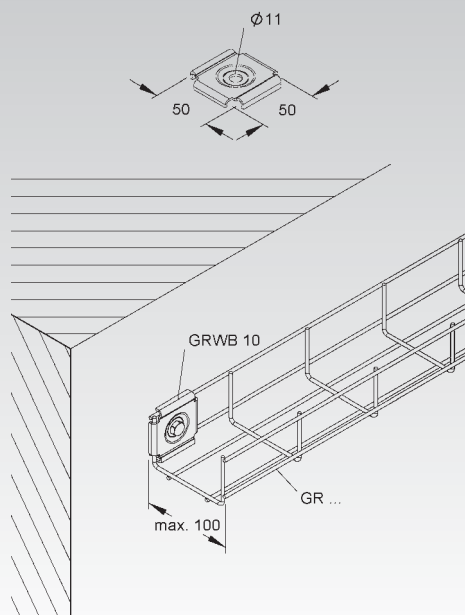

## Center Hanger

for wire mesh tray, two parts

model no.	EAN code	Weight per 100 pc. kg
<b>S</b> GRKB 10	280704	10
<b>F</b> GRKB 10 F	280759	10

for centered hanging of wire mesh tray (50 mm length wire distance) with threaded rod



56

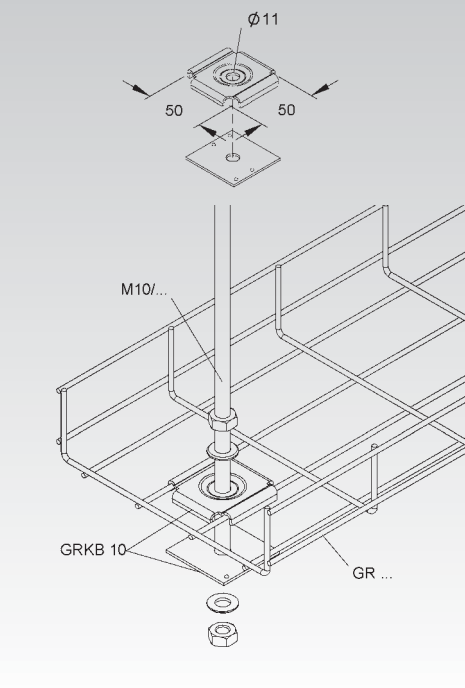

## J - Hook Bolt

model no.	thread	EAN code	Weight per 100 pc. kg
<b>V</b> GRSM 6	M6	280506	1
<b>E3</b> GRSM 6 E3	M6	343799	2,7

to fix wire mesh tray on brackets

stainless steel finish, with hexagon nut and washer  
electroplated finish, with serrated flange nut

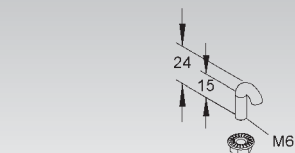

## Trapeze Hanger Clip

model no.	EAN code	Weight per 100 pc. kg
★ F GRAB 10 F	280780	7,7

for all wire mesh tray, max. wire gauge 5 mm  
for single or doublesided hanging of wire mesh tray with threaded rod

To be used for: GR..., GRS..., GRC... and GRCI... type wire mesh tray (max. width 100 mm for single sided and 300 mm for double sided hanging)

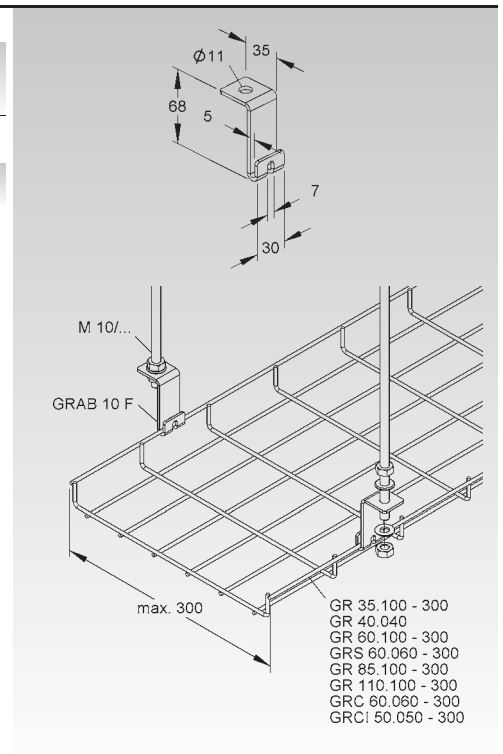



## Mounting Bracket

for wire mesh tray

model no.	EAN code	Weight per 100 pc. kg
<b>F</b> GRMB 50	864904	8,5
<b>E3</b> GRMB 50 E3	912018	8,5

for wall mounting of wire mesh tray with a max. width of 100 mm and for centered hanging of wire mesh tray (max. width 300 mm) by threaded rod

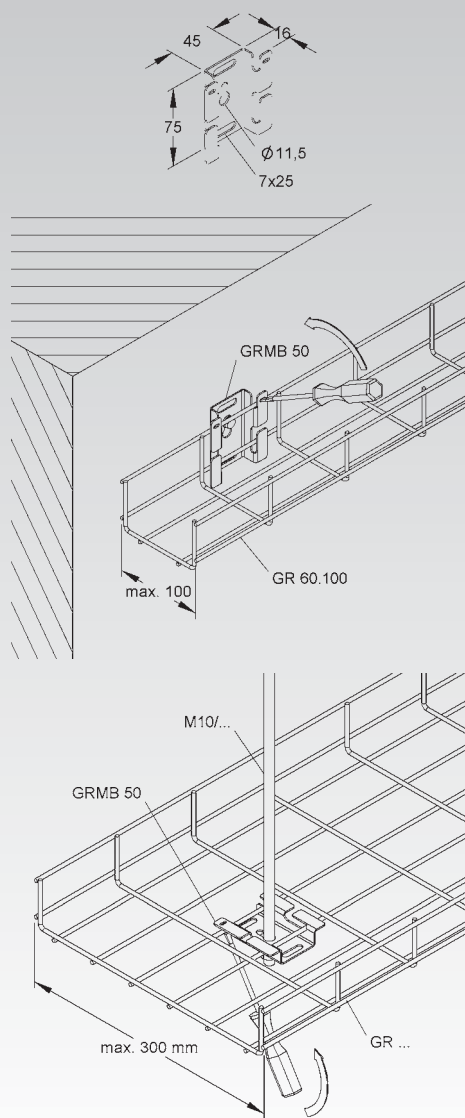

## Extension for Wire Mesh Tray Hanger

model no.	length (A) mm/Inch	EAN code	Weight per 100 pc. kg
<b>F</b> GRTS 30/3 F	3000/117	895182	86,6

for extending GRHB 30/150 F ceiling mount bracket

25 mm center distance in between longholes 9x18 mm

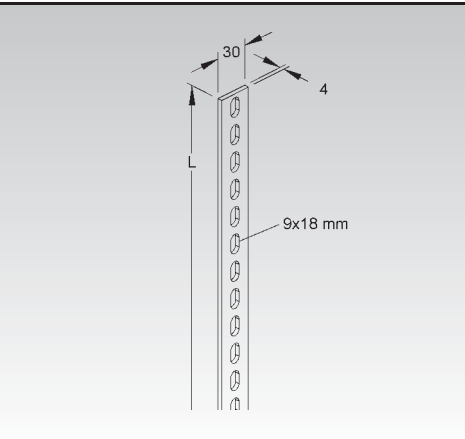

## Mounting Bracket for Wire Mesh Tray

simple

model no.	height (H) mm/Inch	length (A) mm/Inch	EAN code	Weight per 100 pc. kg
<b>F</b> GRHB 30/150 F	71,5/2,8	86,5/3,4	895168	27

for wall mounting wire mesh tray (max. width 100 mm)

use either one GRTS 30/3 or one GRSH 30/ for ceiling mount of wire mesh tray (max. width 200 mm)

use either two GRTS 30/3 or two GRSH 30/ for ceiling mount of wire mesh tray (width > 200 mm)

**Wire mesh tray mounted to the ceiling (width > 200 mm) needs extra crosswise support against deflection under heavy load**

boltless fixing in the bottom of the tray

use an extra J - Hook bolt to protect wire mesh tray from tilting

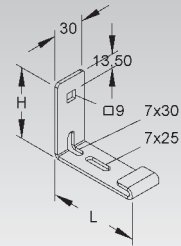

## Mushroom Head Bolt, similar to DIN 603 Standard

model no.	thread	length (A) mm/Inch	strength category	EAN code	Weight per 100 pc. kg
<b>F</b> FLM 8 X 16 F	M8	16/0,6	8.8	206704	2,2

HDG finish, flange nut included



## Standard Hanger for Wire Mesh Tray

model no.	height (H) mm/Inch	length (A) mm/Inch	acc. incl.	EAN code	Weight per 100 pc. kg
<b>F</b> GRSH 30 F	170/6,6	86,5/3,4	1 FLM 8x16 F	895199	45

for ceiling mount

boltless fixing in the bottom of the tray

25 mm center distance in between longholes 9x18 mm

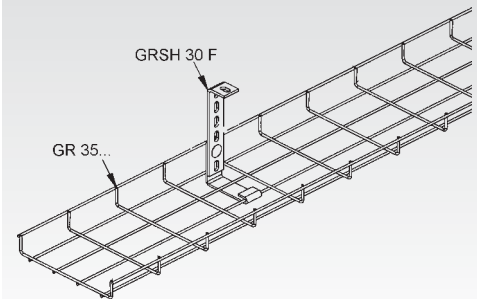
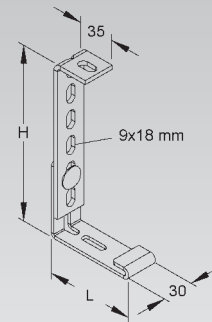

# WIRE MESH TRAY SYSTEM ACCESSORIES

## Overhead Hanger for Wire Mesh Tray

model no.	length (A) mm/Inch	EAN code	Weight per 100 pc. kg
F GRHS 30/150 F	150/5,8	909421	15
F GRHS 30/200 F	200/7,8	909445	18
F GRHS 30/300 F	300/11,7	909469	25
F GRHS 30/400 F	400/15,6	909483	33
F GRHS 30/500 F	500/19,5	909506	40
F GRHS 30/600 F	600/23,4	909520	48
F GRHS 30/700 F	700/27,3	909544	55
F GRHS 30/800 F	800/31,2	909568	63
F GRHS 30/900 F	900/35,1	909582	70
F GRHS 30/1000 F	1000/39	909605	88

for wall or ceiling mounting of wire mesh tray

25 mm center distance in between longholes 9x18 mm

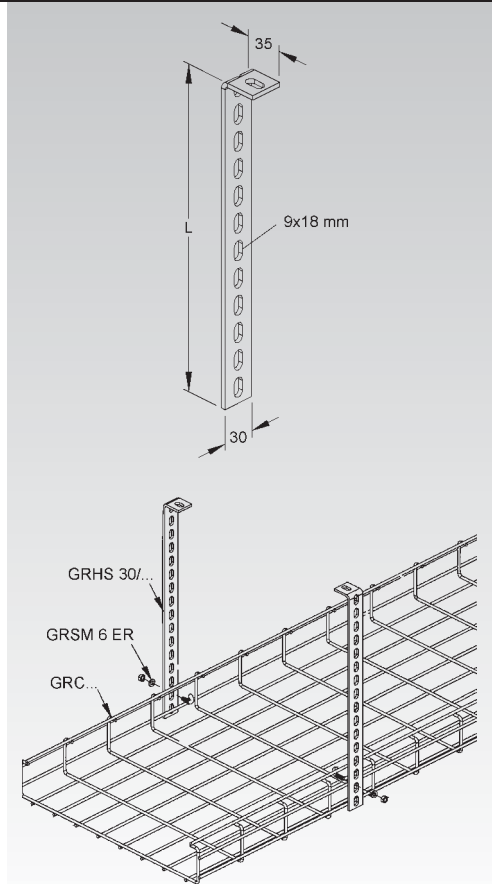

## Horizontal 90° Bend Kit for Wire Mesh Tray

model no.	height (H) mm/Inch	width B mm/Inch	acc. incl.	EAN code	Weight per 100 pc. kg
F GRWV 20/250 F	20/0,8	250/9,8	4 GRSM 6	280452	

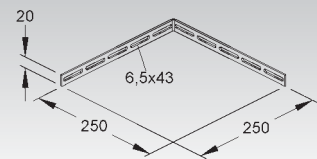

## Universal Mounting Bracket GRB...

model no.	EAN code	Weight per 100 pc. kg
V GRB 4/6.4	930784	
V GRB 4/8.4	930791	
V GRB 4/12.3	930807	
V GRB 4/16.2	930814	
V GRB 4/20.2	930821	
V GRB 4/24.1	930838	

for raised mounting in under floor applications, for spaced wall mounting and for trapeze overhead hangers with threaded rods

Mounting brackets have to be ordered separately.

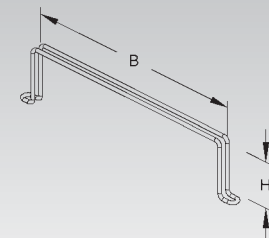

## Attachment Bracket

model no.	EAN code	Weight per 100 pc. kg
V GRBB 6 V	922949	

To be used for: Universal Mounting Bracket GRB...

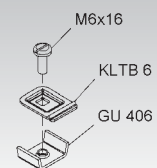

### Cover for Wire Mesh Tray

model no.	width B	thick-ness (t)	EAN code	Weight per 100 m kg
	mm/Inch	mm/Inch		
<b>S</b> GRD 60	60/2,3	0,75	909346	55,6
<b>S</b> GRD 100	100/3,9	0,75	909360	78
<b>S</b> GRD 150	150/5,8	0,75	909384	109
<b>S</b> GRD 200	200/7,8	0,75	909407	139
<b>S</b> GRD 300	300/11,7	0,9	922000	239
<b>E3</b> GRD 60 E3	60/2,3	0,8	801206	57
<b>E3</b> GRD 100 E3	100/3,9	0,8	801251	83
<b>E3</b> GRD 150 E3	150/5,8	0,8	801220	115,6
<b>E3</b> GRD 200 E3	200/7,8	0,8	801305	146
<b>E3</b> GRD 300 E3	300/11,7	0,8	801374	210,6

To be used for: snap-on cover for wire mesh tray type GR... and GRS...  
hot-dip galvanized finish available on request

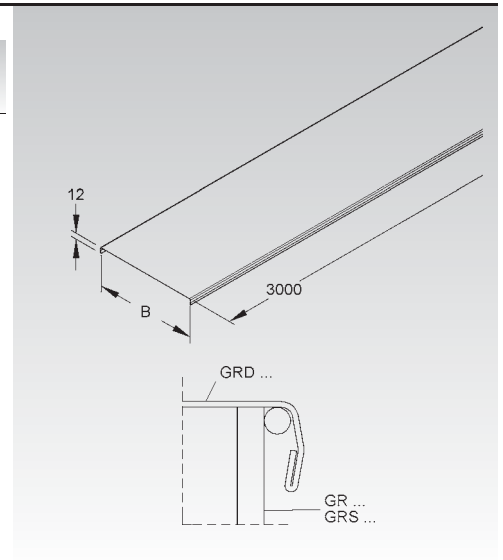

# WIRE MESH TRAY SYSTEM

## Boltless Connectors needed per interconnection

Gitterrinnen Modell-Nr.	Anzahl Stück	Verbinder Modell-Nr.	Position der Verbinder	Gitterrinnen Modell-Nr.	Anzahl Stück	Verbinder Modell-Nr.	Position der Verbinder
GR 35.100 GR 35.100 F GR 35.150 GR 35.150 F GR 35.200 GR 35.200 F GR 35.300 GR 35.300 F GR 35.400 GR 35.400 F	2       3	GRVS 4 GRVS 4 E3 GRVS 4 GRVS 4 E3 GRVS 4 GRVS 4 E3 GRVS 4 GRVS 4 E3	install one on each side at upper wire      install one on each side at upper wire and one in the center of the bottom	GRS 160.200 GRS 160.200 F GRS 160.200 E3 GRS 160.300 GRS 160.300 F GRS 160.300 E3 GRS 160.450 GRS 160.450 F GRS 160.450 E3 GRS 160.600 GRS 160.600 F GRS 160.600 E3	4       4	GRVS 5 GRVS 5 E3 GRVS 5 E3 GRVS 5 GRVS 5 E3 GRVS 5 E3 GRVS 5 GRVS 5 E3 GRVS 5 E3 GRVS 5 GRVS 5 E3 GRVS 5 E3	install one on each side at upper wire and two uniformly distributed in the bottom       install one on each side at upper wire and two uniformly distributed in the bottom
GR 60.100 GR 60.100 F GR 60.100 E3 GR 60.150 GR 60.150 F GR 60.150 E3 GR 60.200 GR 60.200 F GR 60.200 E3 GR 60.300 GR 60.300 F GR 60.300 E3 GR 60.400 GR 60.400 F GR 60.400 E3 GR 60.500 GR 60.500 F GR 60.600 GR 60.600 F	2       3  4	GRVS 4 GRVS 4 E3 GRVS 4 E3 GRVS 4 GRVS 4 E3 GRVS 4 E3 GRVS 4 GRVS 4 E3 GRVS 4 E3 GRVS 4 GRVS 4 E3 GRVS 4 E3 GRVS 4 GRVS 4 E3 GRVS 4 E3 GRVS 4 GRVS 4 E3 GRVS 4 GRVS 4 E3	install one on each side at upper wire       install one on each side at upper wire and one in the center of the bottom  install one on each side at upper wire and two uniformly distributed in the bottom	GR 85.100 GR 85.100 F GR 85.200 GR 85.200 F GR 85.300 GR 85.300 F GR 85.400 GR 85.400 F GR 85.500 GR 85.500 F GR 85.600 GR 85.600 F	3  4	GRVS 4 GRVS 4 E3 GRVS 4 GRVS 4 E3 GRVS 4 GRVS 4 E3 GRVS 4 GRVS 4 E3 GRVS 4 GRVS 4 E3 GRVS 4 GRVS 4 E3	install one on each side at upper wire and one in the center of the bottom  install one on each side at upper wire and two uniformly distributed in the bottom
GRS 60.060 GRS 60.060 F GRS 60.060 E3 GRS 60.100 GRS 60.100 F GRS 60.100 E3 GRS 60.150 GRS 60.150 F GRS 60.150 E3 GRS 60.200 GRS 60.200 F GRS 60.200 E3 GRS 60.300 GRS 60.300 F GRS 60.300 E3 GRS 60.400 GRS 60.400 F GRS 60.400 E3 GRS 60.500 GRS 60.500 F GRS 60.500 E3 GRS 60.600 GRS 60.600 E3	2       3  4	GRVS 4 GRVS 4 E3 GRVS 4 E3 GRVS 4 GRVS 4 E3 GRVS 4 E3 GRVS 5 GRVS 5 E3 GRVS 5 E3 GRVS 5 GRVS 5 E3 GRVS 5 E3 GRVS 5 GRVS 5 E3 GRVS 5 E3 GRVS 5 GRVS 5 E3 GRVS 5 E3 GRVS 5 GRVS 5 E3 GRVS 5 E3	install one on each side at upper wire       install one on each side at upper wire and one in the center of the bottom  install one on each side at upper wire and two uniformly distributed in the bottom	GR 110.100 GR 110.100 F GR 110.200 GR 110.200 F GR 110.300 GR 110.300 F GR 110.400 GR 110.400 F GR 110.500 GR 110.500 F GR 110.600 GR 110.600 F	4	GRVS 4 GRVS 4 E3 GRVS 4 GRVS 4 E3 GRVS 4 GRVS 4 E3 GRVS 4 GRVS 4 E3 GRVS 4 GRVS 4 E3 GRVS 4 GRVS 4 E3	install one on each side at upper wire and two uniformly distributed in the bottom
GRS 60.060 GRS 60.060 E3 GRS 60.100 GRS 60.100 E3 GRS 60.200 GRS 60.200 E3 GRS 60.300 GRS 60.300 E3 GRS 60.400 GRS 60.400 E3 GRS 60.500 GRS 60.500 E3 GRS 60.600 GRS 60.600 E3	2  3  4	GRVS 5 GRVS 5 E3 GRVS 5 GRVS 5 E3 GRVS 5 GRVS 5 E3 GRVS 5 GRVS 5 E3 GRVS 5 GRVS 5 E3 GRVS 5 GRVS 5 E3 GRVS 5 GRVS 5 E3	install one on each side at upper wire  install one on each side at upper wire and one in the center of the bottom  install one on each side at upper wire and two uniformly distributed in the bottom	GRC 60.060 GRC 60.060 E3 GRC 60.100 GRC 60.100 E3 GRC 60.200 GRC 60.200 E3 GRC 60.300 GRC 60.300 E3 GRC 60.400 GRC 60.400 E3 GRC 60.500 GRC 60.500 E3	2  3  4	GRVS 5 GRVS 5 E3 GRVS 5 GRVS 5 E3 GRVS 5 GRVS 5 E3 GRVS 5 GRVS 5 E3 GRVS 5 GRVS 5 E3 GRVS 5 GRVS 5 E3	install one on each side at upper wire  install one on each side at upper wire and one in the center of the bottom  install one on each side at upper wire and two uniformly distributed in the bottom
GRS 110.200 GRS 110.200 F GRS 110.200 E3 GRS 110.300 GRS 110.300 F GRS 110.300 E3 GRS 110.450 GRS 110.450 F GRS 110.450 E3 GRS 110.600 GRS 110.600 F GRS 110.600 E3	4       4	GRVS 5 GRVS 5 E3 GRVS 5 E3 GRVS 5 GRVS 5 E3 GRVS 5 E3 GRVS 5 GRVS 5 E3 GRVS 5 E3 GRVS 5 GRVS 5 E3 GRVS 5 E3	install one on each side at upper wire and two uniformly distributed in the bottom       install one on each side at upper wire and two uniformly distributed in the bottom	GRL 60.090 GRL 60.090 F	1	GRVS 4 GRVS 4 E3	install one on one side

For the universal slice plate GRV 6, ...F, ...E3 take the same amount of pieces as given in above table.

